



Carmarthenshire  
Shopfront Design  
Guide 2022

[01 Introduction](#) 3

[02 The benefits of a well-designed shopfront](#) 5

[03 Setting the scene](#) 6

[04 The challenge](#) 10

[05 The parts of a shopfront/ prevailing character](#) 12

[06 Contemporary Design within Traditional Buildings](#) 25

[07 Formal approvals](#) 27

[08 General policies and design principles](#) 29

[09 Design guidance of a shopfront](#) 32

[10 Using colour on shopfronts](#) 46

[11 Short to medium term solutions](#) 47

[12 Further guidance](#) 48

[13 Glossary](#) 48

For more information or advice please contact the Carmarthenshire County Council Built Heritage Team at: [BHConsultations@carmarthenshire.gov.uk](mailto:BHConsultations@carmarthenshire.gov.uk)

This report and all intellectual property rights in it and arising from it are the property of or are under licence to Donald Insall Associates or the client. Neither the whole nor any part of this report, nor any drawing, plan, other document or any information contained within it may be reproduced in any form without the prior written consent of Donald Insall Associates or the client as appropriate. All material in which the intellectual property rights have been licensed to DIA or the client and such rights belong to third parties may not be published or reproduced at all in any form, and any request for consent to the use of such material for publication or reproduction should be made directly to the owner of the intellectual property rights therein.





This design guide has been produced by Donald Insall Associates for Carmarthenshire County Council, funded through a grant from the Community Renewal Fund, to provide guidance for the improvement, alteration, replacement, and restoration of shopfronts within Carmarthenshire. The purpose of this design guide is not to suggest precise ways of designing shopfronts, or to focus on a particular town or place, but to help celebrate the character of historic shopfront design within the county and support the regeneration of towns to ensure their continued commercial success.

This guide will be used by both Carmarthenshire County Council and local Town Councils to help in assessing planning applications for shopfronts and signage.

The guide is also intended to support local architects, designers, traditional builders, craftspeople and artists in recognising the important contribution made by understanding our shared heritage, valuing it and investing in it. Artistic creativity and the growth of traditional craft and building skills are key to the life of our historic places across the county, and are encouraged and celebrated in line with the wider work at the Tywi Centre. [Home | Tywi Centre](#)



### Owner Or Business?

Are you interested in improving your shopfront? You can use this design guide, combined with historic research, to find out what is the best design approach to suit you, your business, and the building you are in.

Is your building listed or in a Conservation Area, or does it have surviving historic features? Are you keen to think creatively about design? Use this guide to understand your building and test a series of design options. If you wish to use an architect or designer, this will help you work with them to achieve your design aspirations whilst ensuring the quality and style is in keeping with the building and its surroundings. For further guidance on finding out about your building, use the links below:

Find out if your building is listed: [Search Cadw records | Cadw \(gov.wales\)](#)

Find out if your building is in a Conservation Area: [My Nearest - Planning information \(gov.wales\)](#)

Appraisals for selected Conservation Areas can be found at: [Conservation Areas Consultation \(gov.wales\)](#)

CADW Advice and Guidance documents: [Listed Buildings | Cadw \(gov.wales\)](#)

Carmarthenshire County Council Advice and Guidance documents: [Listed buildings \(gov.wales\)](#)

Carmarthenshire records for building history: [Carmarthenshire Archives \(gov.wales\)](#)

### Architects And Designers?

Please use this guide as a checklist. Not all headings may apply but they can help in guiding your client to the best options for their building and the permissions which may be required.

We encourage you to research the history of the building on which you are working, and its place in the wider history of its surroundings. This will ensure that the design will complement the building and its wider surroundings. It is expected that evidence of this research will be referenced within the final design, whether this be through a new design, or the careful repair and reinstatement of a historic shopfront. Historic shopfronts also offer a unique opportunity for creativity, for example through engaging signwriters and artists to bring the shopfront to life and attract trade. Although this guidance provides information on how to ensure new shopfronts enhance their surroundings this does not mean that historic designs are the only solution which will be accepted. Creativity is urged and the contemporary interpretation of historic principles is supported and encouraged. The use of local craftspeople and skills will also be looked on favourably.

### Town Council Or Community Representative?

We encourage you to use this guide to help you review planning applications and comments on design proposals.

Share your local knowledge about the history of buildings within your town and encourage businesses, building owners, designers and architects to respond to local character.



Shopfronts are highly visible, prominent, and important elements of a town's streetscape because they are located at ground floor level, usually spanning the entire width of a building, often projecting into the street.

While the purpose of a shopfront is to attract shoppers' attention to the products inside and sell the brand, the whole street needs to be appealing, and work together to create a coherent streetscape of which everyone can be proud. Research shows that a well-designed shopfront has a number of other social and economic benefits for business and building owners, including those below:

- Reflects the quality of what is for sale inside the shop
- Attracts new customers leading to increased foot fall and sales
- Can attract higher rental value
- Gains better publicity and becomes a place which people talk about
- Aids the local economy through attracting new customers who in turn spend money elsewhere
- Encourages others to invest in their own properties and improve places as a whole
- Makes places feel safer for all





Carmarthen

Carmarthenshire has a rich and multi-layered history which helps define the character of many of the county's towns. There are 27 Conservation Areas within Carmarthenshire, recognised due to their special architectural and historic interest, as well as 1,854 listed buildings and 370 scheduled monuments which stands testament to the significance and quality of architecture within the county. Shopfronts can be a vital part of this character and as such, it is essential to understand how the shopfronts you are working with sit within the history of the town and how they contribute to this character.

Many of the towns within Carmarthenshire have a shared history, with the earliest commercial activities granted by Royal charter throughout the 12th – 14th Centuries, allowing open markets and fairs to be held. As such, the marketplace was typically a focal point of early town development with street names such as Market Street, Market Lane, and Hall Street still evident in many places. These provided places of commerce, not just for local townspeople, but also for stationed garrisons and trade which sustained and in turn helped towns grow and develop.

Within the 17th and 18th Centuries, Town Halls and Guildhalls were commonly built to integrate these open markets within their lower floors, providing shelter below and space for administrative functions above. In Carmarthen the Guildhall had a marketplace and corn market, in Kidwelly the town hall was a covered market, and in Newcastle Emlyn the Cawdor Hall acted as a marketplace adjoined to the cattle market behind.



Late 18th Century Shopfront



Also key to the economy of many towns in this period, particularly Llandeilo and Newcastle Emlyn, were the drovers, who drove livestock to market and on fair days cattle and horses would have filled the streets. The drovers were key figures in the annual fair and were the lifeblood of a town's inns. A number of towns in the county retain this connection with agricultural markets, with Newcastle Emlyn preserving its cattle market in its 18th Century location.

The importance of ports, and later road and rail travel to the commercial development of towns cannot be understated. This helped grow not just domestic trade, but also foreign trade and additionally supported more inland locations. The growth of trade brought with it not just shops and industry, but the gentry, wealthy merchants, and traders who in turn built townhouses, created jobs and encouraged cultural and public buildings to be built. Within the 18th and 19th Centuries, these establishments included coffee houses, inns, warehouses, banks, private residences, educational establishments, professional offices, commercial and public buildings. The historic shopfronts which survive today, either in whole or part, are typically from this period, reflecting the new found wealth of many towns. The commercial High Streets we recognise today are primarily a product of this time.

Within the 19th Century this also included the arcades within Ammanford and Llanelli, designed and constructed in red brick, of three storeys and are grade II listed. Although many of the shopfronts have been altered, the form and intent of these structures remains and their presence within the town centres is a large part of their character and identity as a shopping district.



Mid 19th Century Shopfront



Late 20th Century Shopfront



Newcastle Emlyn

Although the historic marketplaces from which many of Carmarthenshire's towns grew are typically no longer used as such, the historic street patterns which have evolved from these commercial centres can often still be recognised, through squares or focal points at crossings and junctions. It is no secret that the High Street is struggling following the COVID pandemic and the digitalisation of our shopping habits, but this struggle is not new.

In the late 20th Century, the high street faced competition from shopping malls; pedestrianisation schemes were hastily implemented and historic buildings lost and plots infilled with new buildings with large open floor plates to compete. Shopping centres, such as St Ellis in Llanelli, Merlin's Walk and St Catherine's Walk shopping centres in Carmarthen were created, sometimes to the benefit and sometimes to the bereft of the historic shopping districts.

There is much investment in the High Street in the UK today through development and investment in the public realm and building regeneration. Marketplaces and local produce are coming back to town centres and historic marketplaces are providing space and opportunity to reignite town centres and encourage visitors.

Investment in historic shopfronts drives regeneration. Defining, conserving, and restoring what is special about a particular street, village or town sparks and develops public awareness about the special character of the place, helps the community and visitors appreciate their surroundings, and encourages people to value special historic places, to enjoy them and to use them. This 'virtuous circle' of defining, appreciating, valuing and enjoying heritage acts as a catalyst for neighbouring buildings and areas to in turn value their heritage – so joined-



up heritage-led regeneration can really help change the character of an area and the spirit of a place, fuelling economic growth. This Guidance can be used to support such grant schemes for Carmarthenshire historic towns in terms of regeneration and growth to support sustainable towns across the county.

Historic or Modern - it's all in the design.

We are fortunate that the many historic shops have survived across Carmarthenshire, and continue to provide so much character to our towns. This is testament to their quality, not just in their craftsmanship but crucially in their design.

Although there is much shared history, each town has its own story which has created characteristics which are unique to that place. This may be through the scale, form or use of buildings, or the materials and details which define them. The character of places can also equally be dependent upon their contemporary interventions from the early 20th Century to the present day and their contribution should not be overlooked. It is therefore important that new interventions, whether these be contemporary takes on historic design, or replicas of what has been lost, recognise the special qualities which make up the character of these places, so that this can be preserved, enhanced, and support the continued commercial success of the county's towns.

The images set out here illustrate the variety seen throughout the county and recognise some of the high-quality historic shopfronts which survive.



Llandeilo

We want to celebrate Carmarthenshire's towns and support their continued success. However, there is room for improvement and the loss of historic shopfronts, poor commercial signage and shutters can contribute to a general reduction of quality. The loss of traditional shopfronts within towns since the latter half of the 20th Century, as well as the unauthorised replacement of windows and signage appears to be a common issue in most places, some towns to a worse degree than others. The fast-changing retail industry can put pressure on buildings to respond rapidly and often. However, this can often be to the detriment of the individual characteristics of the building and wider appearance of a place. It is our collective responsibility to create change which preserves what is special and enhances that which has been lost. The following list highlights some of the more widely seen issues throughout the county:

1. The loss of vertical divisions to maximise the width of the shopfront at ground floor level which in turn does not respond to upper storeys
2. The use of materials and colours which are out of character with their surroundings
3. Overly large signage which is out of proportion with the building, or which covers up surviving historic details
4. The loss of stall risers which help add solidity to the ground floor
5. The loss of historic hanging signs
6. A one-size-fits all approach, particularly to chain stores, without consideration of the individual characteristics of a building









## 05 The Parts Of A Shopfront

Fanlight



Cornice



Fascia



Console Bracket

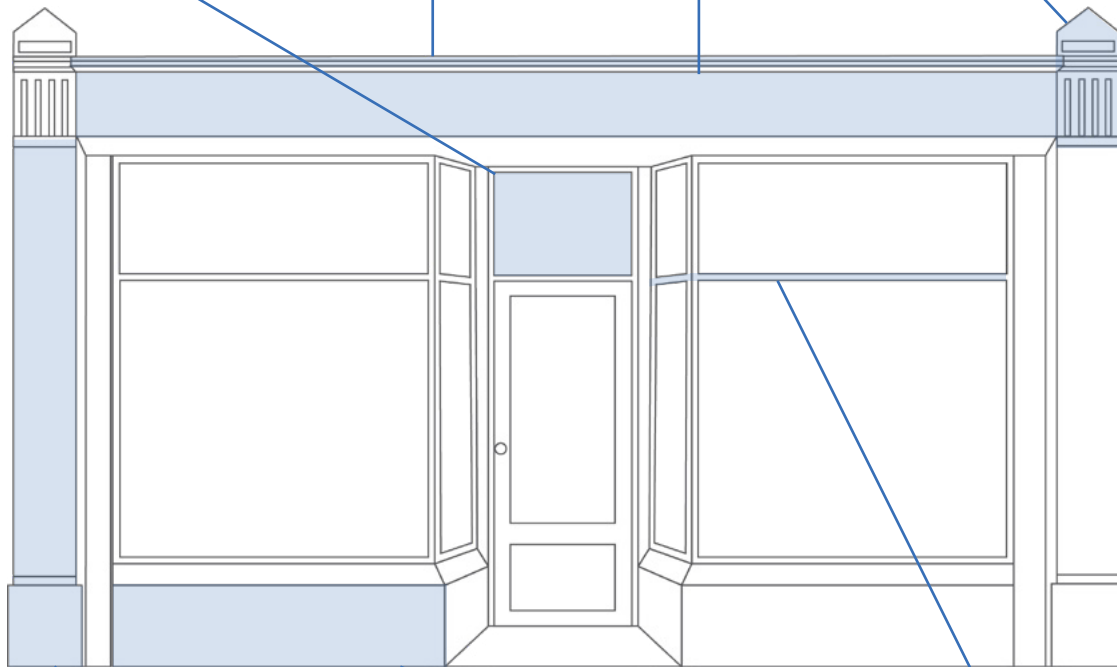

Pilaster



Stall-riser



Transom

As illustrated through historic photographs and surviving examples, historic shopfronts were traditionally of high quality and detailed timber construction within the ground floor. Above the ground floor window would be a timber fascia with hand painted sign, set between corbels or console brackets and pilasters which helped define the separation between buildings. These were typically timber, but there are examples of stone brackets. A stallriser below the window was typically timber, but examples of tile, stone and render were also common, alongside recessed doorways. Shopwindows were usually subdivided, with fanlights or vertical divisions. Hanging signs, awnings and lighting added additional articulation to the shopfront and in turn the street. Earlier 19th Century or late 18th Century shopfronts often had multi-paned shopfronts with examples of bowed windows which projected out from the shopfront. Early 20th Century examples followed a very similar approach, but often with stained glass and smaller panes integrated into fanlights and arch headed windows with more delicate and refined joinery details. The following pages illustrate examples from Carmarthenshire demonstrating the variety and quality of these elements.



### Fanlight

Fanlights are glazed areas, often decorative, which sit above an entrance door and provide daylight into a shop. They are often used for displaying the building name or number. Examples within Carmarthenshire are typically rectangular and are most successful when they correspond in height to the window transom (the horizontal division between the upper and lower sections of a shopfront window). Where fanlights have been boarded over, these should be uncovered and glazing reintroduced.



### Cornice

A cornice is a horizontal decorative timber moulding which sits above the fascia at the top of the shopfront. It provides protection from the weather to the shopfront below as well as character and visual interest. It also provides visual support to the shopfront as a whole. There are examples throughout the county of decorative ironwork being installed over the cornice to add further interest, as well as leadwork to protect the timber from rain. The cornice can either sit above the console brackets, with the brackets visually supporting the cornice, or between them.





### Console Brackets

Console brackets, or corbels, are decorative timber sections which sit at the top of the pilasters, donate the extents of the shopfront, and visually integrate the fascia and cornice with the pilasters. There are a number of designs seen within the county, including scrolled, carved, and fluted. Where there are neighbouring buildings which share a similar shopfront design, there should always be two console brackets where the buildings meet, helping to define each property. They are often the most decorative element of a shopfront and therefore play an important part in enhancing its character and appearance.



**Pilaster**

Pilasters play a key role in defining the shopfront, separating the façade from neighbouring properties, visually supporting the fascia and/or cornice and defining the vertical emphasis of the shopfront. They stand proud of the shopfront and are typically painted timber, although there are examples of rendered pilasters within the county. As with console brackets, designs include plain faced pilasters, those with grooves running their length, recessed and projecting patterns. Pilasters can be used to break down large shopfronts into a number of smaller facades. Where shopfronts run over several buildings, pilasters should be integrated on each of the constituent building lines. Where there are neighbouring buildings of similar design, adjoining pilasters can be shared but must be of sufficient width to provide a visual separation.





### Stall-riser

The stallriser is a solid band at ground floor level which provides a base for the shopwindows to sit upon. They also provide protection from passing foot traffic and weather and are therefore typically of a solid material. Although timber examples can be seen, within the county stallrisers are most typically rendered, with examples of brick (where the host building is also brick) and glazed tiles. A projecting window cill should sit above the stallriser. They also provide the opportunity to sensitively integrate services such as ventilation through the incorporation of grilles.

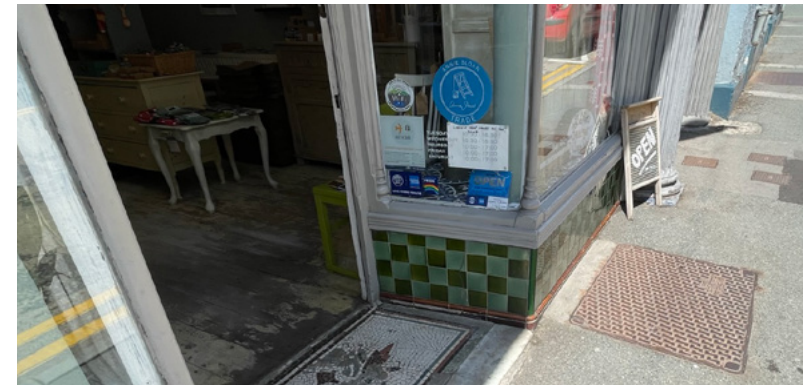

**Fascia**

The fascia is an integral part of the design of a shopfront. The scale should not dominate, and it should sit between the console brackets and/or pilasters and below the cornice. They should not obscure details of the shopfront or project beyond the pilasters. Within the county, fascia are typically painted timber with handwritten signs and provide an opportunity for occupants to be creative and express the nature of the shop within. Traditional lighting can be integrated into the fascia or positioned above the cornice to illuminate it.





**Hanging signs**

Carmarthenshire has a strong tradition of hand-painted hanging signs on shopfronts and the county retains a number of skilled craftspeople who can successfully do this. Hanging signs add character without being visually intrusive and enable greater advertising while respecting the carefully balanced design of a traditional shopfront. There are many wonderful examples of hand-painted hanging signs across the county, most commonly in painted timber with fixed ironwork brackets, with the colour and lettering design mimicking that on the fascia. Hanging signs can add greatly to a streetscape, but it is important that they are not overly large, or they can create clutter and obscure shopfront details.

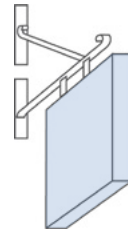

**Windows**

Windows are naturally the most dominant feature of a shopfront and therefore require careful thought. They should reflect the fenestration within the whole building and be bordered by pilasters, cornices, console brackets and the stall-riser. Window frames should be in painted timber, divided vertically and horizontally to break down otherwise large and flat areas of glass. The mullions (vertical bars) and transoms (horizontal bars) can vary in design, from thinly carved timber sections to wider timber pieces. Glazing should be clear, but often within the county you see upper sections using stained glass to add colour and interest.





### Doors

The design of the door should be considered as a part of the overall design of the shopfront. Where possible it should be centrally located with shop windows either side. Within the county doorways are typically recessed providing articulation to the street scene and protection for customers from the weather. Doors should be of painted timber using the same design and colour as the windows. The height of the lower panel should replicate the height of the stallriser. Traditional door designs are typically 4 paneled with the upper section often glazed. A large upper glazed panel with small kick plate is also commonly seen.



### Security

Security considerations often entail the addition of security grilles and gates. Where shops have recessed entrances, these are most often protected with open ironwork gates which can fold back when the shop is open. Solid roller shutters create a poor impression of a town and can often attract vandalism rather than deter from it. Internal grilles are generally preferred as they allow the shop to remain visible out of hours whilst still providing the required level of security.

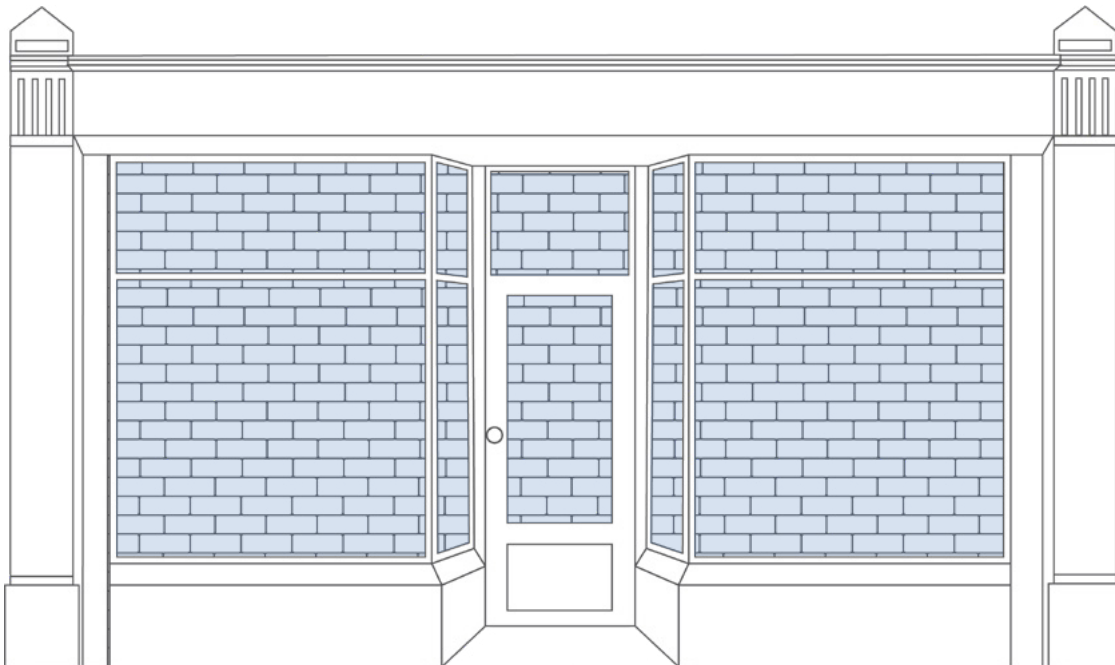



### Awnings

Awnings or canopies can add life and character to a street but if inappropriately detailed or scaled can also detract from the overall appearance of a shopfront. Blinds should be able to be retracted when not in use, with blind boxes integrated into the shopfront design, located under the fascia, and extending its entire width. They should be made from fabric and set between the pilasters and complimentary in colour to the shopfront.

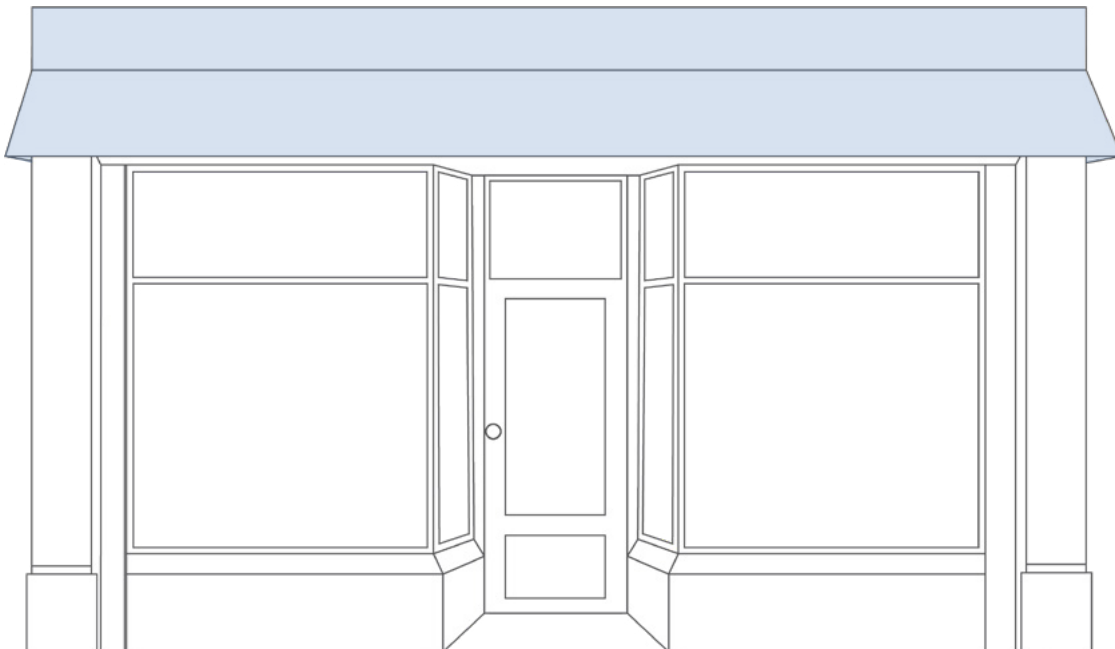

### Recessed thresholds

Recessed entrances are common throughout the county and can encourage visitors to enter a shop and provide additional window space for shop owners. The floors within these areas also provide a space for creativity and examples of colourful and detailed stone and mosaics can be seen throughout the County, sometimes integrating shop and building names. Care should be given that the floor is non-slip.

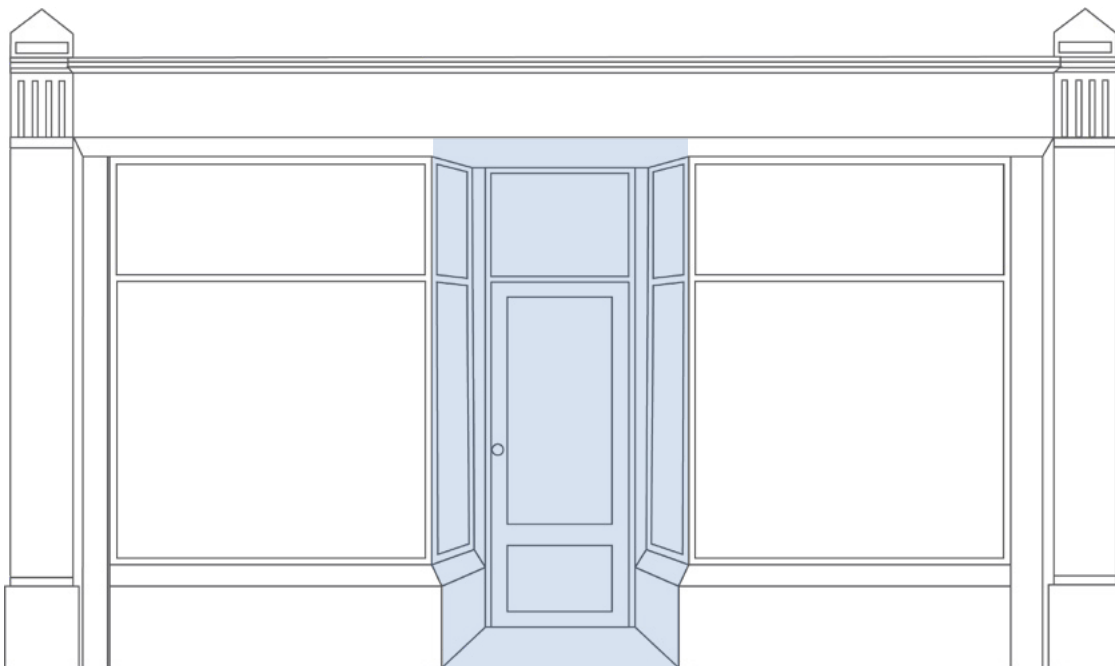



Good contemporary design can produce innovative and eye-catching shopfronts and can be successfully integrated into traditional buildings by following the broad principles contained within this guide. For contemporary designs to be successful they need to respect the architectural form of the building into which it is being incorporated, as well as its surroundings. Ideally this would incorporate the elements and materials of a traditional shopfront (as set out in section 5), but variation can be bought in the considered design of each of these features. For example, this could be through contemporary signwriting, architectural details to joinery or the colour scheme.

It is essential that the context of the shopfront is considered as part of the design and the details which are unique to the town and/or street into which the shopfront is being integrated are respected. For example, Newcastle Emlyn has a large quantity of early 19th Century shopfronts which are distinguished by a single window with separate entrance, whereas Carmarthen typically has mid-19th Century shopfronts which incorporate the whole width of the building. Variation can also be seen within the design of console brackets, fanlights, door type and material throughout the county. For example, in Llandeilo there are several stallrisers in glazed tiles whereas in Carmarthen these are typically timber or render. As such, it is recommended that this guide be used as a checklist to study the elements of the shopfronts within the town and understand the common forms and materials which should be used to base the shopfront design upon.

There is not a preference within this guide for either a contemporary or historically inspired approach, although it should be demonstrated that the principles discussed here have been respected in either case. Every design will be considered on a case-by-case basis and an explanation of how the principles set out here have been respected should be included within the application. If the principles have not been used, it should be demonstrated how the shopfront design respects its surroundings and the building into which it is integrated.



*Contemporary shopfront design in a traditional style.*



*Early 19th Century shopfront in Newcastle Emlyn.*



*Mid 19th Century shopfront in Carmarthen.*





© YOU&ME Architecture

© YOU&ME Architecture



### Planning Permission

The wholesale replacement of shopfronts and or significant alterations, generally requires planning consent. Advertisements or external painting for the purposes of advertisement or direction, may require a separate application for advertisement consent. However, routine maintenance works, such as redecoration in a similar colour scheme, cleaning, or like-for-like repairs does not usually require planning consent. The following are examples of those which would require a planning application:

- The wholesale replacement of an existing shopfront
- Material alterations such as the installation of security shutters or canopies
- The removal of historic features

The planning process will consider the commercial needs of the retailer/ occupier, how they wish to present their business and the needs of the shopfront, building, and street scene. Whilst there are no prescribed colours for individual towns, it is expected that the choice of colour and finish will be appropriate and mindful of the historic context and will be enhancing to the building and its surroundings.

### Conservation Areas

If your property is within a Conservation Area, consent may be required for items which would not normally require permission. Permitted development rights may also be removed by an 'Article 4 Direction'. Designs within Conservation Areas will be considered against the character of the area, and they must be judged to either preserve or enhance this character.

You can find further information on Conservation Areas at: [Conservation Areas \(gov.wales\)](#)

### Listed Buildings

Any alterations to shopfronts that are part of a listed building will require listed building consent. This includes minor alterations such as:

- The removal of paint or cladding materials
- The replacement of doors and windows
- The installation or removal of fascias, shutters, hanging signs, and awnings
- The installation of new services, such as lighting and alarms

Listed building consent is required to change the colour of a shopfront on a listed building where there is a material change affecting its character and appearance. For instance, where there is a fundamental change of colour. However, where there is merely a variation within the same colour range, this would not normally require consent.

Items which do not require consent:

- Like-for-like repairs
- Redecoration
- Regular maintenance

If you would like further information on which works may or may not require listed building consent, please contact the Built Heritage Team at [bhconsultations@carmarthenshire.gov.uk](mailto:bhconsultations@carmarthenshire.gov.uk).

### Pre-Application Advice

If you are unsure whether consent is required, or would like to understand whether proposals may be considered acceptable, you can apply for pre-application advice at: [Pre-application-service \(gov.wales\)](https://gov.wales/pre-application-service)



**Access For All**

Provision should be made where possible for easy access for people with disabilities as well as prams and buggies. Doorways and entrances should be levelled and/or ramped and wide enough for entry. Where a building is listed, proposals will be judged in their own merit, and it may not be possible to create full level access without adversely affecting the character of the building or surviving historic fabric. Refer to Part M of the Building Regulations which provides guidance regarding the form, dimensions and layout of an entrance to enable access for all users.





### Design Principles

The following are considered the main principles which should be considered when preparing proposals for shopfronts:

- 1.** *Where historic shopfronts have been lost and there are no records of historic design, the new shopfront should relate to the whole building, as well as its neighbors, in terms of proportion, scale, and style to better reveal the design of the building and ensure it sits comfortably within its surrounding*

A shopfront should be thought of as part of the whole building into which it is fitted, whether it be a traditional or contemporary building. When replacing or restoring shopfronts, the details should be determined by the original building, not later inappropriate replacements. If too little remains to understand what the shopfront may have looked like, you may be able to look at neighboring buildings of a similar style and period. Surviving historic shopfronts can be used as a precedent and these principles should be followed to ensure that the special character of the area is preserved.



### **2.** *Common positive features seen in neighboring shops or within an area should be acknowledged*

The character of an area should be preserved, and it is important that designs respond to conventions such as scale, alignment, and symmetry. Inappropriate signs, door and window types, materials and colours can disrupt an otherwise characterful street. Whilst this should not dissuade individuality, respecting the existing character of a place will produce a higher quality design which will encourage visitors.

### **3.** *Surviving historic material should be retained wherever possible and their repair should be carried out using materials appropriate to the age and construction of the building*

The retention of historic features will have a significant positive impact on a building. Additionally, repairs can often be less costly than replacement and by carrying out routine maintenance, buildings will remain in good order and save money over their life. Where possible, sustainable sources of materials should be used and have a life-span appropriate for their use in the building. The repair and reuse of existing materials also ensures that the embodied carbon within the existing construction is not lost.



Set out on the following pages is guidance relating to different shopfront elements, with accompanying photographs to illustrate examples of each. This guidance is aimed at supporting good design rather than dictating a particular design style. It should help ensure the character of existing areas are preserved and enhanced, and as such, each design will be considered on its own merits.

### Windows, Mullions, And Transoms

Windows are an integral part of a shopfront and have a significant impact on character and quality. Windows should be symmetrical and balanced with regard to proportions and the shopfront as a whole, particularly with regard to neighbouring properties and upper storeys.

- Ensure the proportions of windows balance with other features e.g., do not brick up part of a window or isolate a small window. Where possible, original openings which have been badly altered should be reinstated.
- Lineup features e.g., cills, transoms, and fanlights.
- Treatments which restrict views into a shopfront should be avoided e.g., tinted, or reflective glass or large scale/numerous advertisements.
- Large uninterrupted expanses of glass should be avoided. Vertical divisions built into any new shopfront should complement the building into which it is fitted.
- If a shopfront spans more than one building, it should be subdivided accordingly.
- If the shop is part of a terrace which still retains examples of historic windows, consider repeating their pattern. This will help establish continuity within the terrace.

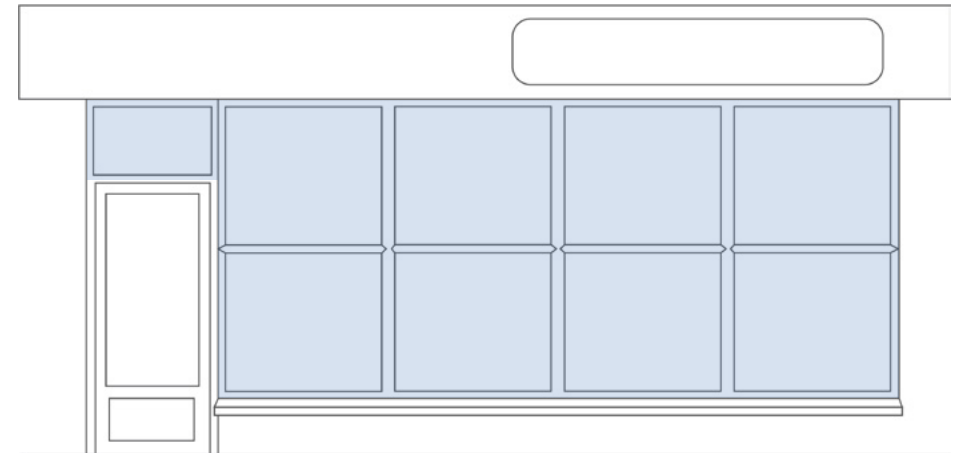

✘ *The window proportions do not relate to the building as a whole or other joinery features such as the door and fanlight.*



✔ *Windows have been subdivided to line up with other features and creates proportions which relate to the building as a whole.*



### Doors and Access

Doors are an area of focus for the shopfront and should reflect the design and character of the building.

- The door/s should complement the design of the shopfront e.g., the bottom panel of the door should relate to the height of the stall-riser and the door material and ironmongery in keeping with the rest of the shopfront
- Doors should retain the proportion of the original opening. The proportion of openings which have been altered to the detriment of the building should be reinstated. Where recessed doorways have survived, these should be retained.
- Generally, four or six paneled painted timber doors should be used for shopfronts, with the option of panels being glazed. Fully paneled doors may be more appropriate for independent access to upper floors but should match in style the main shop door
- If there is a recessed doorway, the flooring should be non-slip with a colour and material appropriate to the shopfront and adjacent paving surface. Mosaic examples can be seen throughout the county.

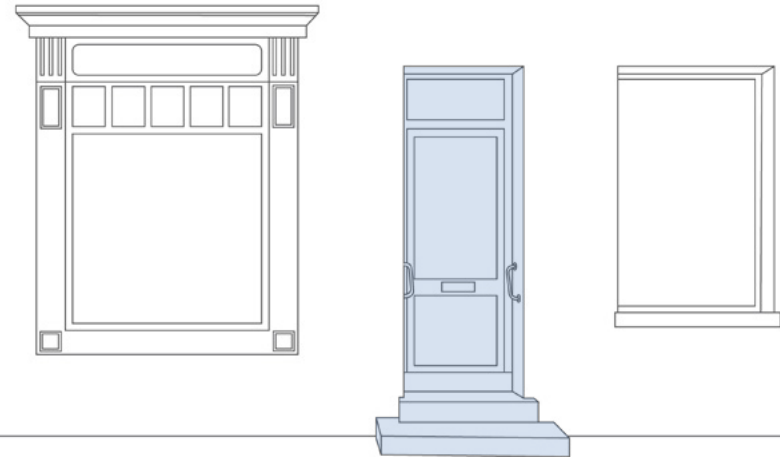

✘ A uPVC door within an original opening, but which does not relate to the shopwindow in terms of material or features.



✔ A traditional paneled door which mimics the design, material and style of the shop as a whole.

### Pilasters And Console Brackets

Pilasters frame and visually denote the extent of a shopfront, supporting other elements and grounding the shopfront within the streetscape.

- Historic pilasters and console brackets should not be removed or obscured by modern signage or equipment on them. Where these have been obscured by contemporary insertions, these should be removed, and the existing features reinstated.
- Surviving examples should be used to replicate or inspire replacements where these have been lost and there is not historic documentation to suggest what these were



✘ Existing brackets have been removed or obscured by a large fascia above. The pilaster has been overclad with an inappropriate material.

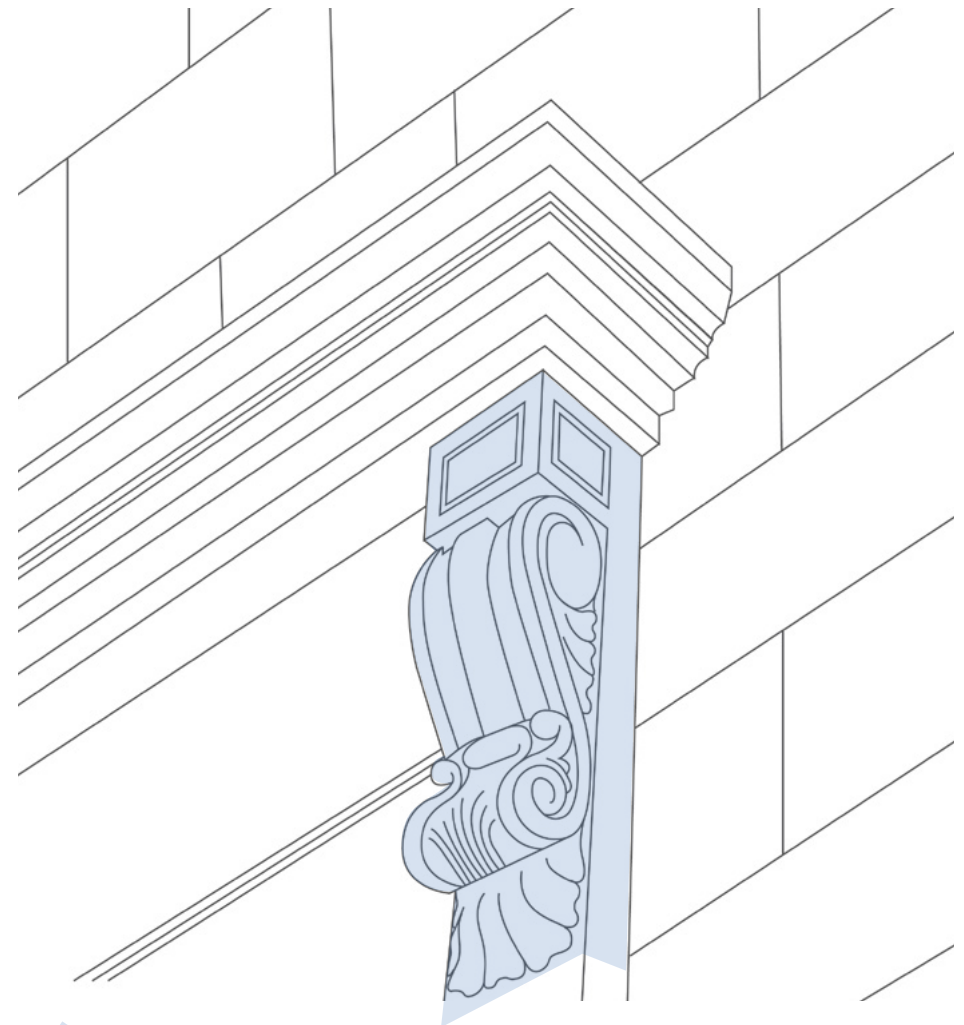

✔ An example of a historic console bracket



## Services

Services are an essential part of any shop but must be detailed and located sensitively to avoid detracting from the building.

- Where mechanical ventilation is necessary, locations for external extract fans or grilles should be kept away from primary street elevations
- For natural ventilation, preferred solutions include opening fanlights or openings integrated within the overall design of the shopfront e.g., decorative grilles within stall-risers
- If items such as alarm boxes and CCTV cameras are considered necessary on street elevations, they should be positioned discreetly without obscuring any architectural features
- Elevations should be kept clear of cable runs
- 



✘ *Prominently placed security alarm which distracts from the shopfront and streetscape*

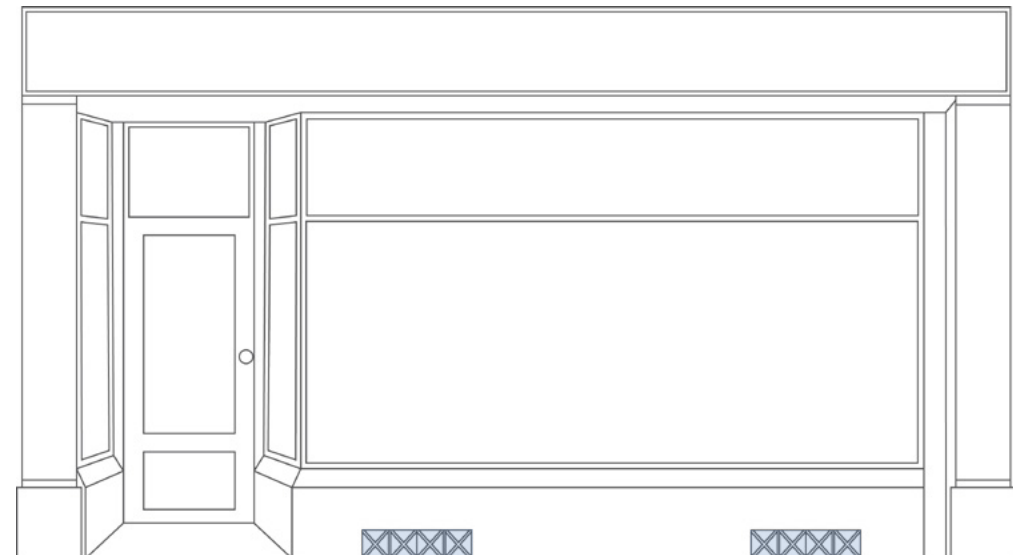

✔ *Traditional solution to ventilation using decorative grilles within the stall-riser*

### Stall-risers

Stall-risers sit between the ground and shopwindows and provide a visual and structural base for the shopfront. Excluding or designing a stall-riser of insufficient height can distract from the design of a shopfront making it appear top-heavy and unbalanced.

- The height of the stall-riser should relate to other elements of the shopfront e.g., the base of the pilasters, entrance door paneling and neighbouring properties which retain their historic features
- The stall-riser can be subject to a high degree of wear and tear, therefore the material used should be robust and hardwearing. The material should reflect that used elsewhere within the shopfront, although other materials may be appropriate. In high traffic areas the introduction of a plinth in a material such as stone, slate or tile may be appropriate to increase durability
- Stall-risers which run over long stretches should be subdividing into panels to add visual interest

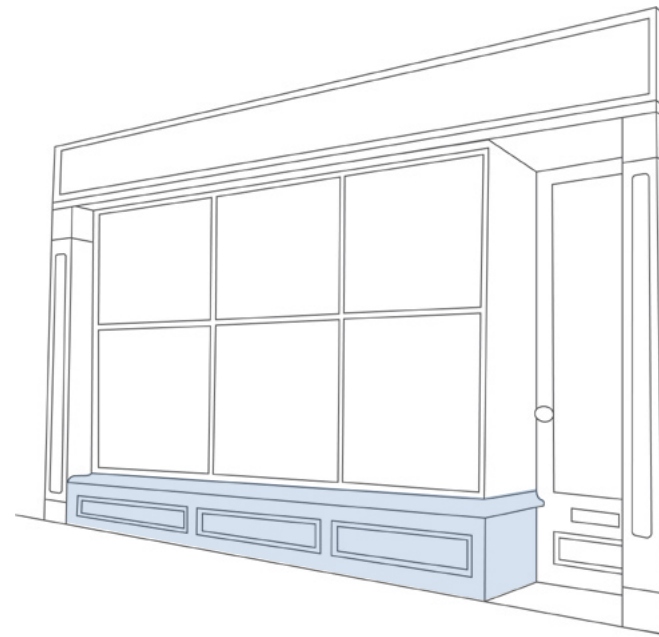

✓ A traditional stall-riser which is sub-divided to relate to the windows above and the height of the lower door panel.



✗ The stall-riser has been increased in height which distorts the proportions of the original shopfront.



### Fascia's, Signwriting And Hanging Signs

These may generally be simple and limited to the relevant information regarding the shop and the services provided, however fascia can also provide an exciting opportunity for creativity to showcase a shop, and Carmarthenshire has a strong tradition of traditional signwriters and artists who can be called on to design something unique, appealing and help identify a shop as uniquely of that place.

- The fascia should be no deeper than the console, located just below the cornice
- Wooden fascia boards with painted lettering or individually applied lettering are preferable on traditionally styled shopfronts
- The lettering should be in proportion with the size of the fascia, typically to the depth of the fascia, leaving a border top and bottom
- Only one projecting sign per shop should be necessary, generally hung at fascia level. Internally illuminated box signs are not appropriate. Fixed brackets are preferred and should be of a design which complements the character of the building
- Hanging signs should be painted timber or stove enameled metal hanging signs of modest size and well-designed proportions, although other materials will be considered. They should be simple and limited to the relevant information regarding the shop and the services provided
- The building number should be included on the fascia
- Box fascia, in particular those which are internally illuminated, will not be permitted.

- Where a shop extends over more than one building, individual fascia should be subdivided accordingly
- Fascia should not obscure, damage or project beyond surviving architectural details, including the cornice and brackets
- Fascia should, where possible, be aligned throughout a terrace which is consistent in form, both in terms of height and proportion. Using several different designs can have a distracting appearance
- Where businesses are located on upper floors, advertisements should be limited to branded signs or hanging signs. Lettering applied to windows may be acceptable if of a suitable size and style to not distract from the building

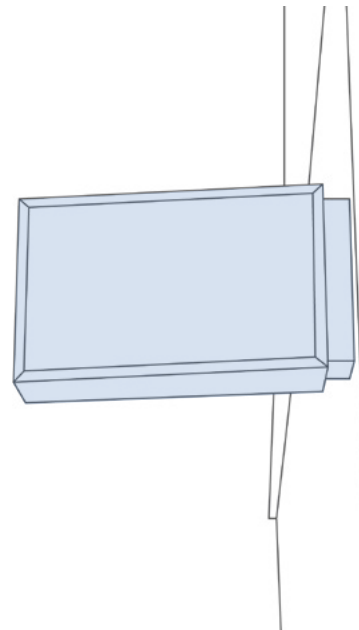

✗ Fixed illuminated signs are out of character in a traditional streetscape.

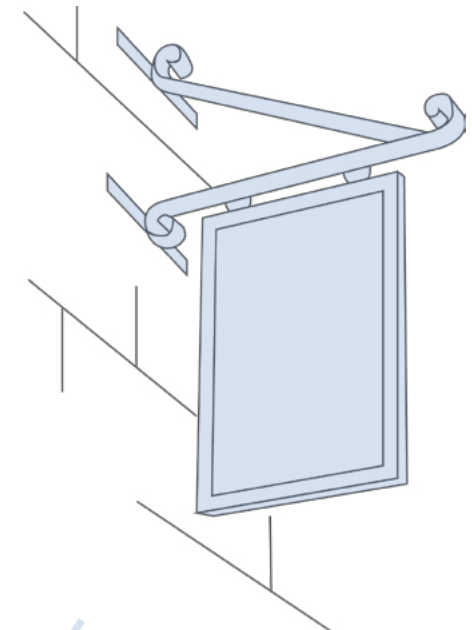

✓ An example of a traditional hanging sign



✘ *Over-scaled fascia with modern lettering which is out of proportion and character with the shopfront below.*



✔ *A well-proportioned fascia with traditional lettering which complements the design of the shopfront below.*



## Canopies and Awnings

Canopies and awnings can provide colour and interest as well as protecting the shopfront and customers from the weather.

- Canopies and awnings should be chosen to compliment the character of the building e.g., a canvas material may be best suited to a traditional property. Dutch fixed canopies, often made from plastic, would be considered inappropriate
- The number, size and shape of canopies should relate to structural openings of the shopfront, with a single canopy limited to a single bay. Long stretches of canopy would be considered inappropriate and they should not cover architectural details
- Canopies should be retractable and allow where possible a minimum of 2.1m headroom with a 1m set back from the edge of the highway
- Canopies should be of a simple design and considered as part of the whole shopfront and not as a contrasting feature. Single colours are likely to be more sympathetic, although proposals which consider multiple colours or patterns will be considered

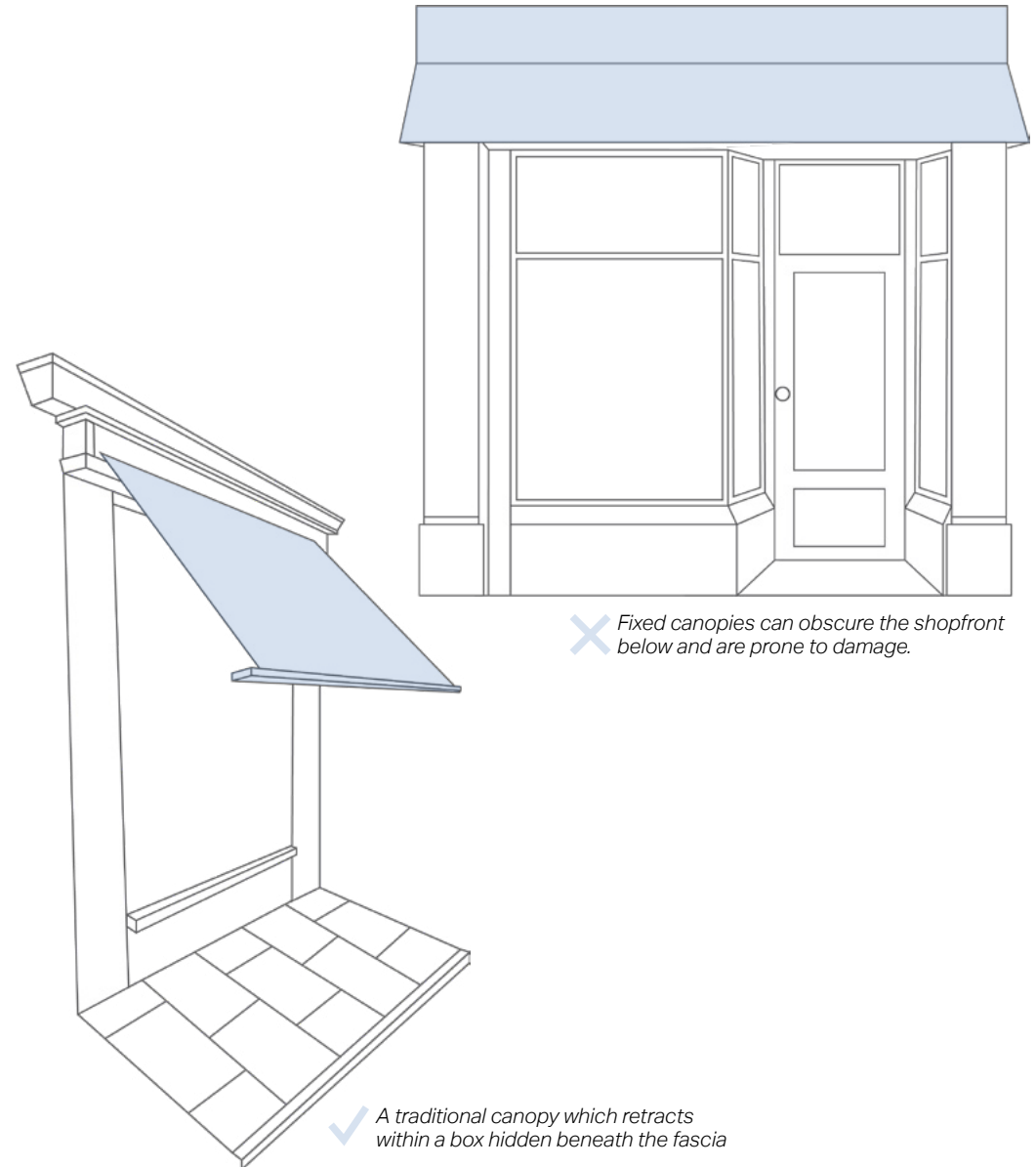

## Security

In recent years, external roller shutters have become a common means of security. Their use has a detrimental effect on the streetscape. The following alternatives should be considered:

- Laminated or toughened glass can be an alternative to shutters and would allow for permanent shopfront advertising.
- Internal lattice and 'brick-bond' grilles have limited impact on the appearance of the shopfront and allow a continued view from the street. Boxes can be located within or behind window heads to allow the grilles to be retracted during the day.
- Removable metal grilles or timber shutters are a traditional solution but require space for storage when not in use.
- External grilles, roller shutters or solid metal shutters will not be permitted
- Traditional gates may be considered where there are recessed entrances that require protection.

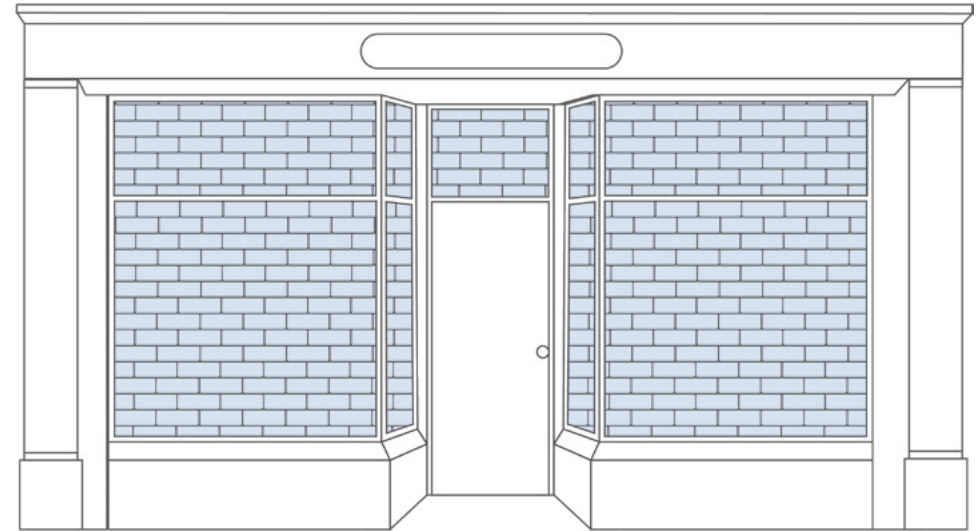

✓ *Internal lattice grilles can be retracted internally and allow the glazing to remain clear when the building is closed.*

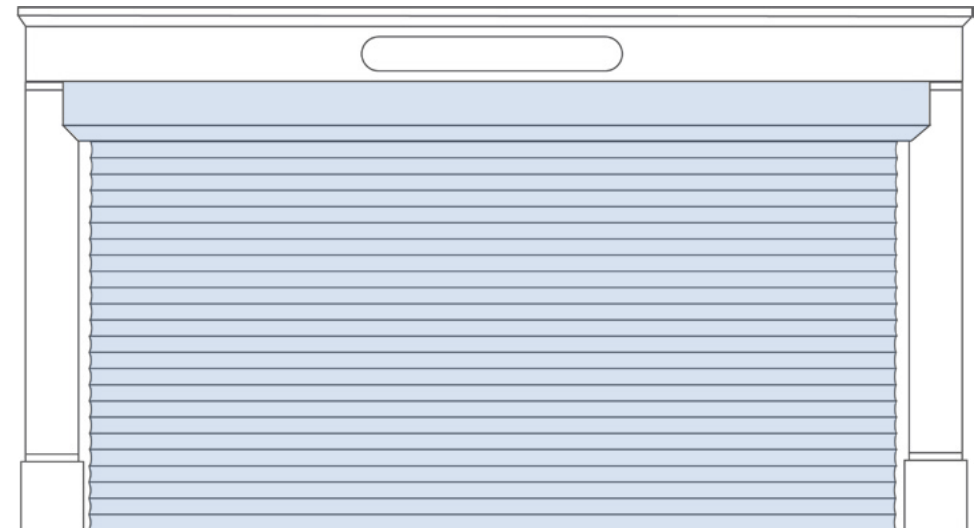

✗ *External roller shutters present a hard image to the street, prone to vandalism, and often require a projecting box to be fitted.*



## Lighting

Well-designed lighting can add interest, illuminate the streetscape at night and create a safe and secure environment.

- Fascia's and/or signage should be illuminated externally. Internally illuminated signs will not be permitted
- Consideration should be given to illuminating individual features on the building's façade, but typically downward lighting will be the most appropriate form
- Multiple projecting fittings can be distracting on a shopfront and prone to vandalism. Advice on appropriate lighting can be sought from the Council although, discreetly installed fittings which illuminate downward and are of a traditional design with a fixed metal bracket coloured in a dark finish will be favoured
- The level of lighting should not adversely affect other properties, should allow the building to be identified and signage to be read. It should not be designed to draw attention to itself
- Discreet lighting of window displays may be appropriate if at a low level and discreetly located

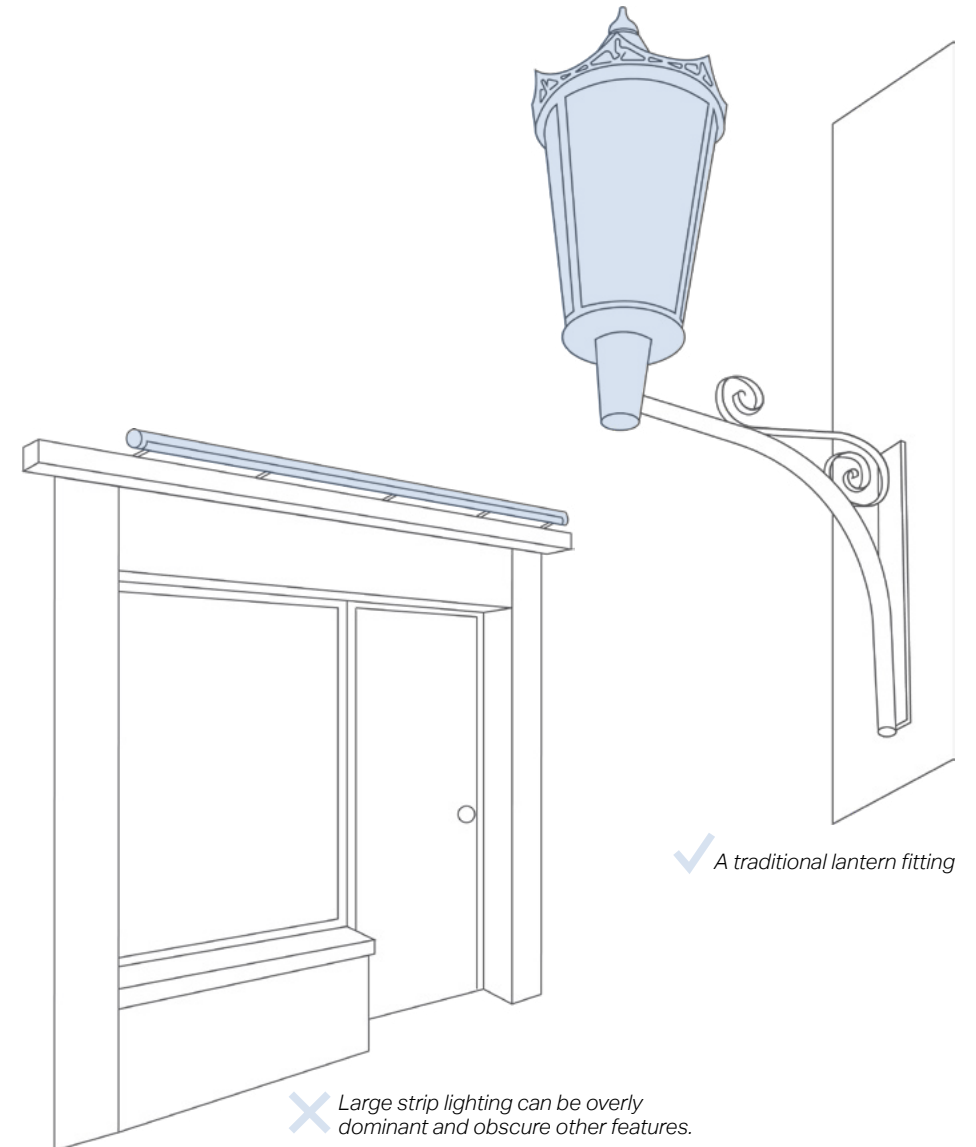

### Colour and Decoration

Colour and decoration are one of the largest visual components of a shopfront and can contribute significantly to the quality of a building and street. A well designed colour scheme can attract visitors, sympathetically integrate a building into its surroundings and compliment the character of a building. See section 10 for more detail on colours.

- To achieve consistency in a streetscape and with the overall character of an area, it is recommended that shopfronts be in a matt or eggshell finish.
- Consideration should be given to highlighting architectural features such as pilasters and consoles using a complimentary colour. These tend to be paler versions of those colours used for joinery.
- Shades of a single colour will generally be considered more appropriate .

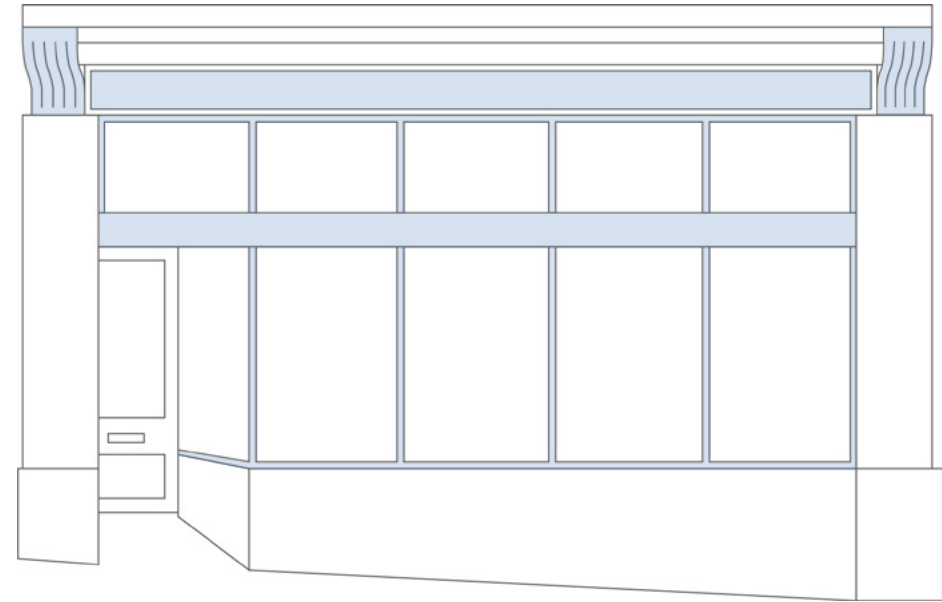

✓ *Colour can be used to highlight architectural features within the shopfront design.*

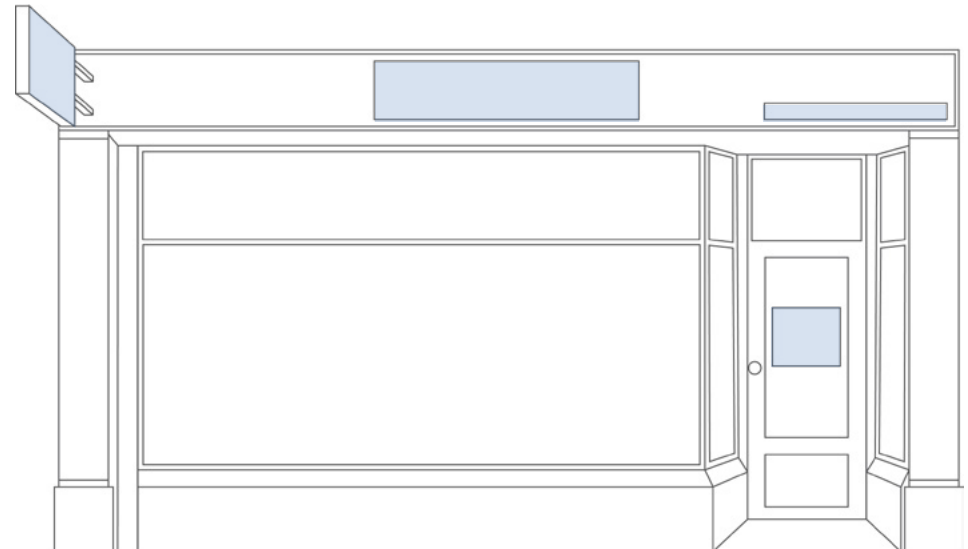

✓ *Complimentary or highlight colours can be used to bring consistency to the design, for example to highlight the shops name*



## Materials

Details should be included with planning applications identifying the choice of materials and finishes. The use of traditional materials based upon historic and local examples is generally preferred. Where original features are repaired or renewed, materials of matching type and quality should be used. The list below is generally accepted as the most appropriate choices for new and replacement shopfronts:

- Timber – Painted softwood or hardwood, detailed in accordance with the character of the building and its neighbours. Early 20th Century examples may have used bronze or darkly painted ironwork.
- Ironmongery – Including brass, bronze, and ironwork. This includes elements such as window and door fittings, ventilation grilles and signage.
- Additional materials – Items such as stall risers may use materials such as glazed tiling or render. Mosaics are common for thresholds.
- The use of inappropriate contemporary materials, or colour, such as Perspex, uPVC, or aluminum, which do not respect the palette of materials within an area or neighbouring building would likely be refused.

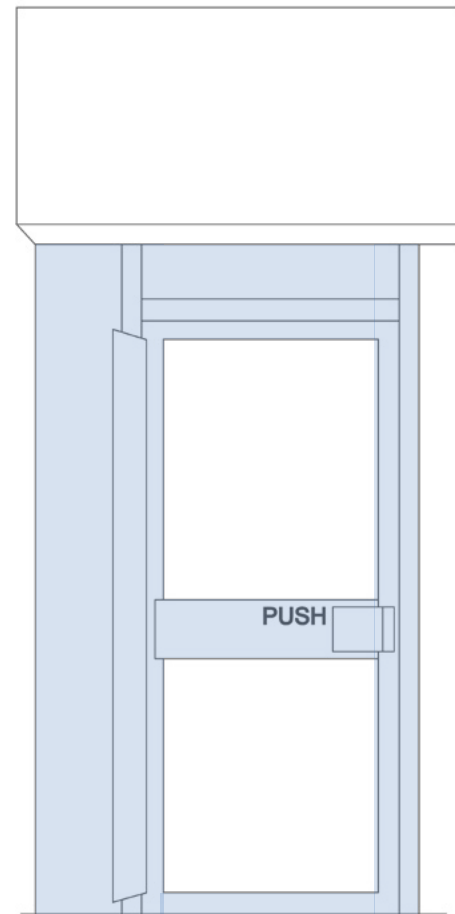

✘ Contemporary aluminum or UPVC doors are out of character in terms of proportions and material.

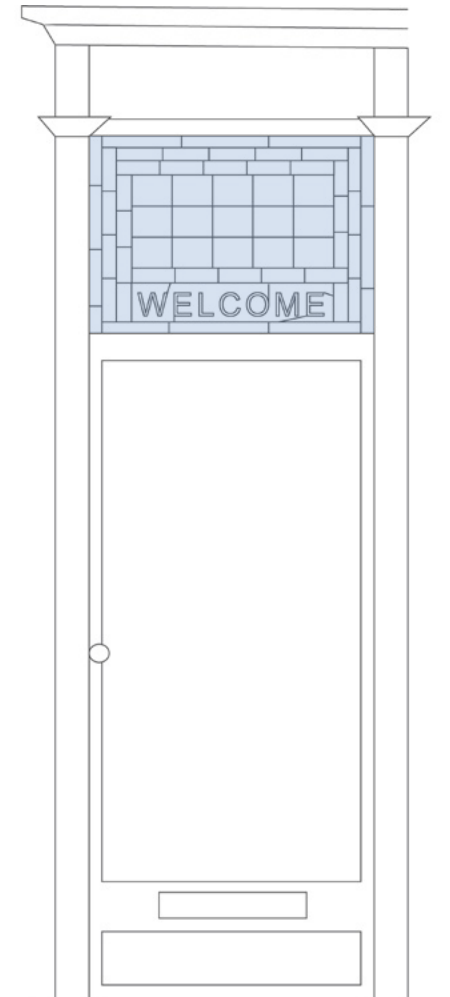

✔ Traditional door design with fanlight, glass panel and solid lower panel.

### Shops adapted from other buildings

When commercial uses are within buildings which were historically used for other purposes, such as a house, it can be hard to integrate signage and advertising sensitively.

- Typically hanging signs would be the most sensitive form of advertising, as these can be located to align with and avoid existing features. Individual letters mounted on minimal pins may be appropriate in some instances. The display of advertisements within windows and through awnings may also be considered appropriate
- The creation of new shopfronts within historic buildings which cause the removal of historic fabric would not be deemed appropriate
- Where two different commercial premises occupy a single building, these should be treated in a way that complement each other

✓ *Integrating signage and fascia sensitively to not obstruct any original features of the building.*

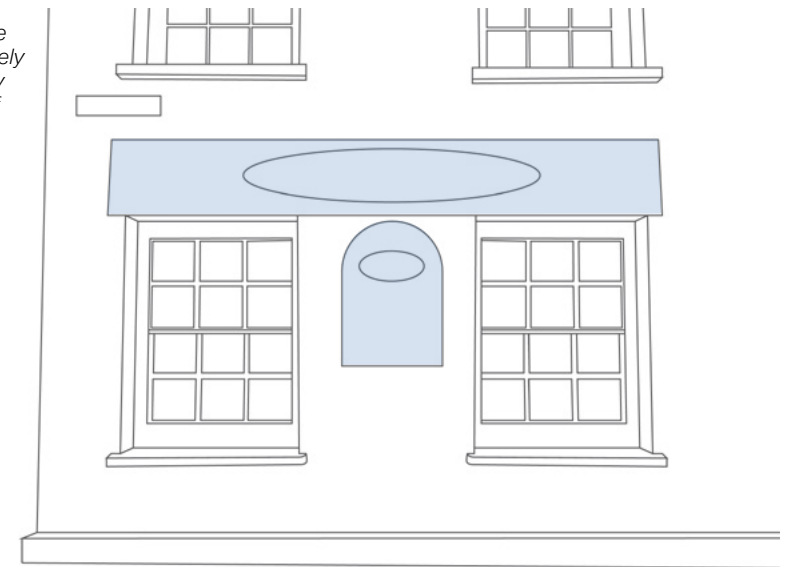

✗ *The creation of a new shopfront in an existing building without taking into account historical features*



### Public realm

The area outside of a commercial building can present an opportunity to display goods and create a vibrant streetscape, however, care must be taken to avoid obstructions and clutter which distract.

- A street trading license is required for tables, seating, and external displays. This can be obtained from the Council Licensing team.
- A clear footpath of 1.8m should be maintained.
- External displays, including the design of A-boards and the choice of external furniture should match the shopfront in terms of material, colour and graphics.





Shopfront colours make a significant and important contribution to the character of a building and street. Shopfronts are highly visible elements and therefore it is critical that the choice of paint colour and finish is appropriate and takes account of and responds to this character. Choosing historically accurate colours is a worthy aim but there should be flexibility to this to allow for some individual choice. However, it is important that there is some consistency, and that choices do not detract from the character of the shopfront, building or street. Neighbouring buildings should be taken into consideration so that there is an integrated and harmonious appearance.

The choice of a colour or colours should not be so bright, strident, or garish, that they would visually detract from the character of the shopfront, host building and street scene. For example, pink, modern brilliant white, bright versions of orange, green and yellow and so on should be avoided and so should modern gloss finishes. Addressing the needs and requirements of chain stores can sometimes be at odds with the use of traditional colour palettes, however, subtle, or muted tones will allow the needs of occupiers to be balanced against the traditional character of a place and a deference to the character of a place is essential. Generally satin and eggshell finishes are the desired approach.



The removal and creation of a new shopfront can be a large-scale undertaking. It may be possible to enhance the appearance of existing shopfronts to the immediate benefit of an area or building through small scale targeted interventions in the short to medium term. Some suggestions are included below:

- Sub-dividing areas of glass to mimic the pattern of a traditional shopfront
- Modern fascia are typically oversized and do not relate to the proportions of a building. Removing and replacing these with a fascia which relates in proportion to the shopwindow below and in line with guidance above,

would immediately improve a buildings appearance

- Where surviving fragments of historic material survive, these should be uncovered and reintegrated into shopfronts. This may involve removing materials which have been applied over or reducing or replacing signage which obscures existing material
- If painted, redecoration in line with the guidance contained in this document would help improve the streetscape
- Where shopfronts are within terraces of a similar style, a joined-up approach to redecoration and signage would immediately restore the uniform character of these properties



© YOU&ME Architecture

For additional guidance of the repair or design of shopfronts, as well as on Conservation Areas within Carmarthenshire, follow the links below:

Advice on listed buildings within Carmarthenshire:

[Listed buildings \(gov.wales\)](#)

[Managing Change in World heritage Sites in Wales \(gov.wales\)](#)

- Architrave: The decorative frame around a door or window
- Corbels or Console bracket: Situated at the top of the pilaster and/or at the end of the fascia to form a bracket, which is often decorative
- Cornice: A decorative trim at the top of the shopfront which gives protection from the weather
- Elevation: The external face of a building
- Façade: The primary elevation of a building including the shopfront and upper floors
- Fanlight: A fixed window above a door or another window
- Fascia: The space where the shop name can be displayed
- Mullion: A vertical post dividing a window or opening into two or more
- Pilaster: A column which separates each shop from its neighbours and defines the width of the shop/ building
- Recessed doorway: An entrance which is set back from the main building line and forms a small lobby area
- Stall-riser: The solid base to a shopfront which provides protection at ground level
- Sub-divided: In relation to shopfronts; 1. Creating divided shopfronts which relate to the building above, even if they form part of a larger unit at ground floor 2. Dividing large areas of glazing into different parts
- Transom: A horizontal bar which separates a door from a window
- Vertical divisions: Creating vertical breaks between shopfront windows to avoid large areas of glass



